

LCD 1200

Category I or Category III Appliance

(see Installation and Operation Manual for venting information)

CODE OPTIONS

CSD-1	UTC Lockout/Reset Control Manual Reset LWCO
--------------	--

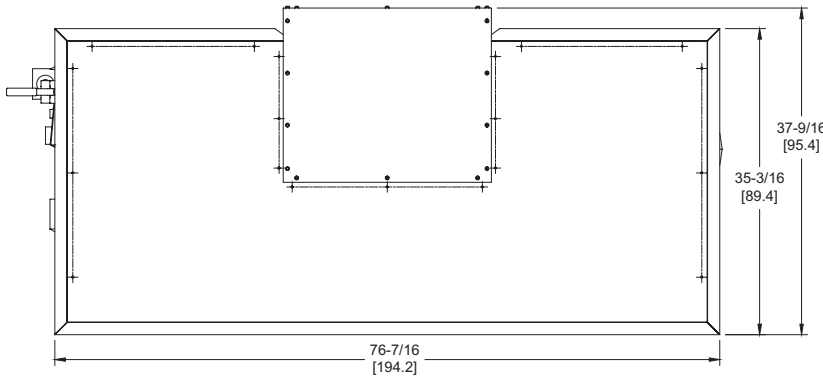

OUTDOOR TOP VIEW

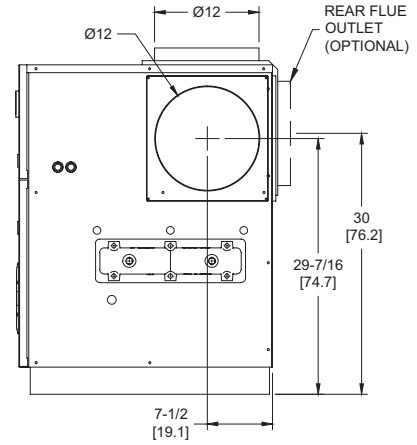

RIGHT VIEW

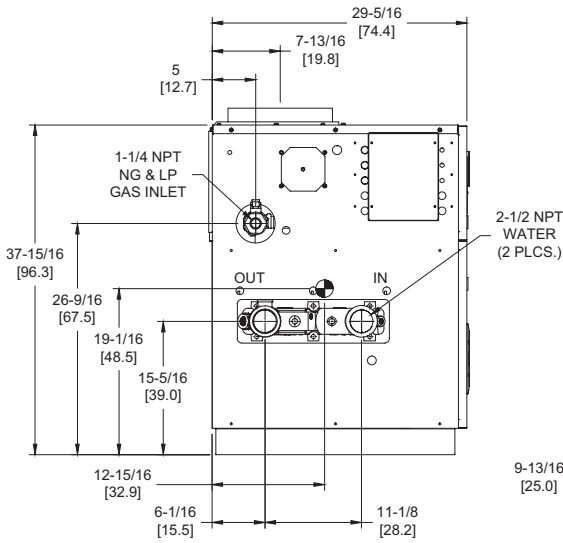

LEFT VIEW

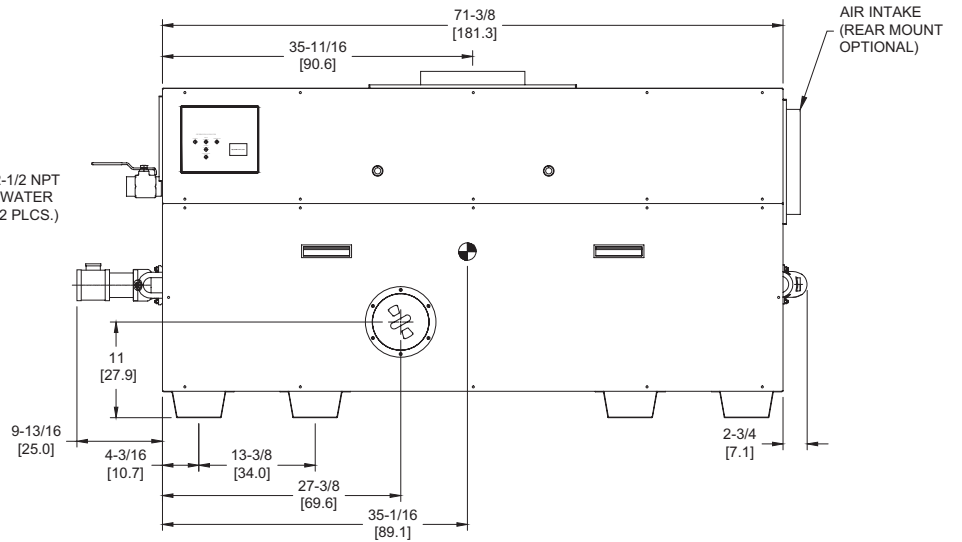

FRONT VIEW

RSUB-20-F

Notes:

1. Dimensions are approximate and should not be used to "rough-in" equipment.
2. Dimensions are subject to change without notice.
3. All dimensions are in inches (cm).
4. ● Symbol indicates center of gravity.

BOILER CERTIFIED RATINGS & CAPACITIES

Fuel Type	Natural/Propane Gas	Boiler FLA	11.0*
Input BTU/hr.	1,200,000 / 352 kW	Min. Gas Pressure Required	7" WC**
Output BTU/hr.	984,000 / 288 kW	Max. Gas Pressure Allowed	14" WC
Electrical Requirements	120VAC/ 1 ph/ 60 hz	Operating Weight	781 lbs. / 355 kg.

BOILER / WATER HEATER TRIM & CONTROLS

Main Gas Valve	Honeywell V8944B 1-1/4"	Pilot Valve	Honeywell VR8205Q
Firing Valve	Honeywell B200T1041 1-1/4"	Air Switch	Cleveland RSS-495
Safety Valve	Honeywell V48A 1-1/4"	Blower Motor	(2) 1/4 hp - FLA 10.2
Ignition Control	UTC 1003-61A	Relief Valve - LW	3/4" x 3/4" set @ 125 psi
Operating Control (LB/LW)	Jumo	Relief Valve - LB	1" x 1-1/4" set @ 50 psi
High Limit (LB/LW)	Jumo	Flow Switch	TACO

A.S.M.E.

ASME Sect IV Htg Surface	109.7 Sq. Ft. / 10.19 Sq. M.	Design Data	Max. 160 psig & 250°F
Water Volume	2.3 gal / 8.8 Liters		

* Add circulator amps.

** For incoming gas pressures lower than 7" WC natural or 11" WC propane, consult factory.

BOILER TEMPERATURE RISE / PRESSURE DROP

20°F / 11.1°C				25°F / 13.9°C				30°F / 16.7°C				35°F / 19.4°C			
Flow Rate		Pressure Drop		Flow Rate		Pressure Drop		Flow Rate		Pressure Drop		Flow Rate		Pressure Drop	
GPM	L/s	Ft	kPa	GPM	L/s	Ft	kPa	GPM	L/s	Ft	kPa	GPM	L/s	Ft	kPa
98.4†	6.2†	8.14	24.0	78.7	5.0	5.38	15.9	65.6	4.1	3.84	11.3	56.2	3.5	2.89	8.5

† Flow exceeds recommended maximum use a greater temperature rise or consult manufacturer.
Cupronickel heat exchanger should be considered.

WATER HEATER HOURLY RECOVERY CAPACITY (GPH & LPH)

40°F	22°C	60°F	33°C	80°F	44°C	100°F	56°C	120°F	67°C	140°F	78°C
2960	11190	1974	7460	1480	5595	1184	4476	987	3730	846	3197

REP FIRM _____
SUBMITTED BY _____
JOB NAME _____
ARCHITECT _____
ENGINEER _____
CONTRACTOR _____
DATE _____

LCD 1200

Category I or Category III Appliance
(see Installation and Operation Manual for venting information)

RBI®
RELIABLE. BOLD. INNOVATIVE.

A Division of Mestek, Inc.
Westfield, MA 01085
(413) 564-5515